

Insulating Rear Cover for 360 Panel System

PN 1331 (1 Module)

Features

- Isolates 360 panel AC components and circuits from DC system elements
- Meets ABYC safety requirements for panels with AC and DC loads
- Provides mechanical protection for panel backs protruding into lockers
- Interlocking companion pieces SIDE, TOP, and END can be stacked to accommodate large AC components
- Cover breakouts allow wire access in any direction
- Includes adapter kit

Specifications

Cover Material	UL94 VO (Flame Retardant) Polycarbonate
Hardware	2 qty. AC cover adapters for select modules
	2 qty. 6-32 x 3/4" Phillips-drive screws
	4 qty. 8-32 x 1/2" Phillips-drive machine screws with captive lock washers
	4 qty. 6-32 x 1/2" Phillips-drive machine screws

Notes:

- Insulating Rear Covers cannot be installed over Push Button Reset-Only Circuit Breaker modules.
- When installed over large source selector rotary switches, covers must be stacked one on top of another (see Figure 5).
- When installing insulating cover over analog and 8200-series digital meters, Systems Monitor 1800, and some DC modules, the included adapter kit is required. (see Figure 3).

CAUTIONS

- ✓ Verify that no DC and AC sources are connected to the vessel's electrical system before installing the Insulating Rear Cover.
- ✓ If an inverter is installed on the vessel, its power leads must be disconnected at the battery before the Insulating Rear Cover is installed.
- ✓ If an AC generator is installed on the vessel, it must be stopped and rendered inoperable before installing the Insulating Rear Cover.
- ✓ For AC/DC combination panels, ABYC compliance requires that when the panel is open, there can be no access to energized AC parts without the use of tools (ABYC E11.11.1.1). To comply, Insulating Rear Covers should be installed over AC circuitry.
- ✓ USCG compliance requires that DC circuitry, not protected by a fuse or circuit breaker, must have a boot or an Insulating Rear Cover (Code of Federal Regulation 183.445).

Guarantee

Blue Sea Systems stands behind its products for as long as you own them. Find detailed information at www.blueseasystems.com/about. For customer service, call 800-222-7617.

Blue Sea Systems Inc.
425 Sequoia Drive
Bellingham, WA 98226 USA

p 360.738.8230
f 360.734.4195
conductor@blueseasystems.com
blueseasystems.com

990344130 Rev.001

Installation

1. To reduce the risk of electrical shock, disconnect all AC and DC power before installation. This includes inverters, generators, shore power attachments, and any other device capable of supplying AC or DC power to the vessel's circuits.
2. Place insulating cover(s) over module(s) to be insulated, aligning captive mounting screws in cover with threaded mounting holes in subframe.
3. Mark which breakouts are to be removed for wires to pass through cover. NOTE: Holes can be drilled in cover instead of removing breakouts.
4. Remove insulating cover, score along selected breakouts with a utility knife, and bend to remove breakouts (see Figure 6). IMPORTANT! For safety, slot or hole size should be close to the diameter of the wire passing through the cover.
5. Replace insulating cover(s) over module(s) and fasten using captive mounting screws.

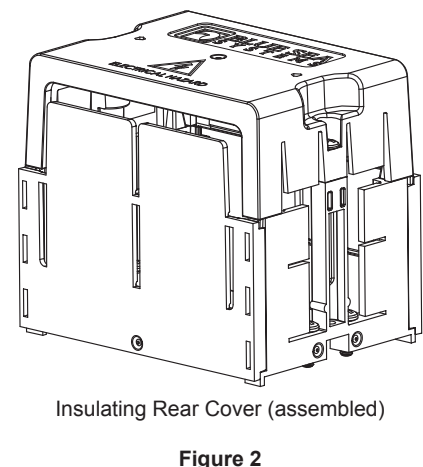
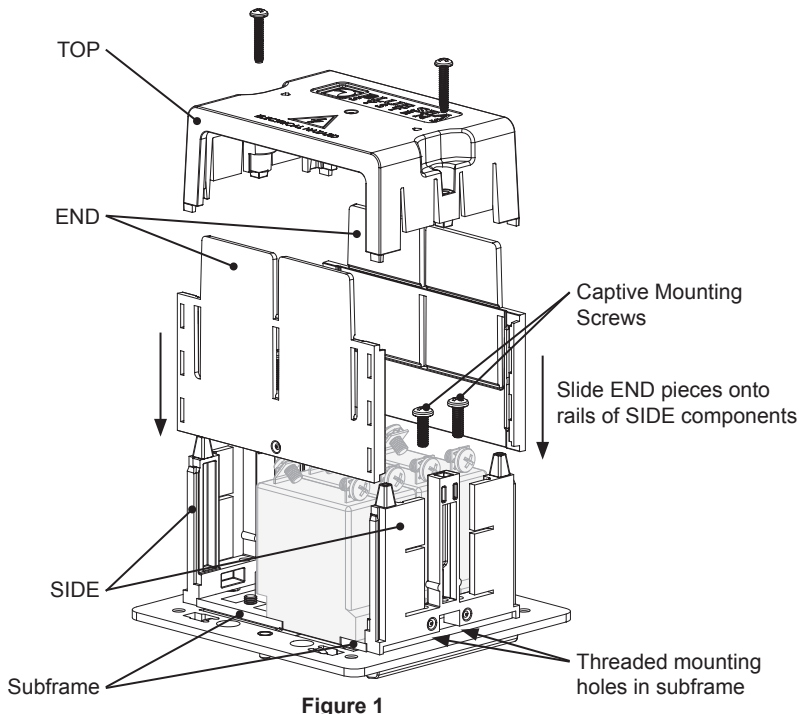

Installing Insulating Rear Cover Over Meter, Systems Monitor 1800, and Some DC Modules

NOTE: When installing insulating cover over analog and 8200-series digital meters, Systems Monitor 1800, and some DC modules, the included adapter kit is required.

1. Remove 4 Phillips flat head bezel mounting screws from subframe.
2. Using longer screws provided in Adapter Kit, attach adapters to subframe. Screws pass through adapters and subframe, and thread into bezel mounting holes.
3. Mount insulating cover as described in steps 2 through 5 above.

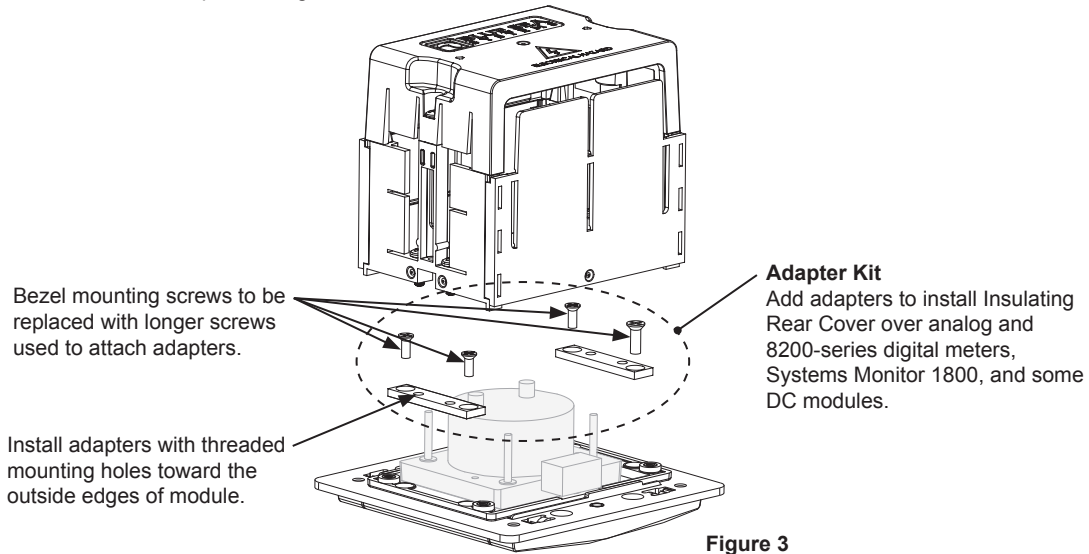

Installing Column of Insulating Rear Covers

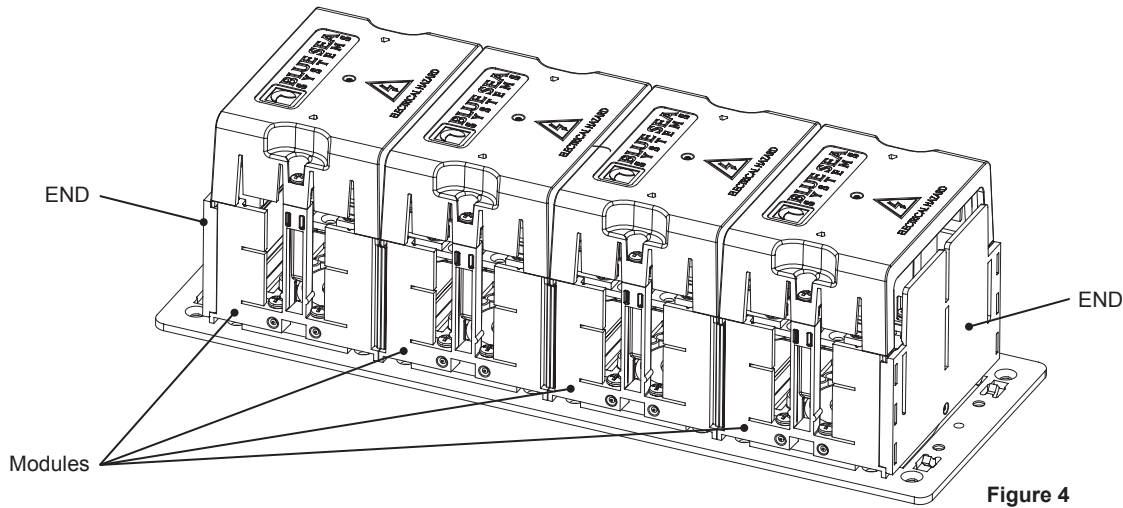

NOTE: When installing insulating covers in columns, use END piece only on both ends of column, not between individual covers.

Stacking Insulating Rear Covers for Tall Components

