



trekMount Solo / Ready User Manual

Overview

trekMount is an all-in-one modular mounting platform designed for use with Victron Energy Systems.

trekMount Solo [Bracket Only] – wire up the system yourself on a bench with mounting holes and cable management already worked out.

trekMount Ready [Pre-Wired, Pre-Programmed, Tested] – the fastest, most user friendly Victron system available. Rapid-deploy. Plug & play. Quick-connect.

trekMount OEM – turn-key, custom, plug & play system for fleet applications with particular space constraints or load requirements.

Features:

- Pre-drilled and tapped mounting holes for 40+ components
- Automated cooling fans included - wiring instructions included
- Mounting hardware included
- Cable management included
- Template for easy placement and mounting
- Lightweight, 1 person install
- Compatible with any battery brand
- Length: 24 in Width: 22.5 in Height: 6.75 in
- Weight: 22 lbs

Table of Contents

[Overview](#)

[Table of Contents](#)

[What's included](#)

[trekMount Solo](#)

[trekMount Ready](#)

[Installing trekMount Ready](#)

[Using the Mounting Template](#)

[Installing Inverter/Charger](#)

[Installing trekMount](#)

[Self Installing components on trekMount Solo](#)

[Mounting trekMount](#)

[Component Wiring Connections](#)

[Connections made by Trek Systems](#)

[Component Wiring Connections \(Continued\)](#)

[Remaining Connections needed](#)

[Startup Procedure](#)

[Connecting to WiFi](#)

[Programming Victron Inverter/Charger Fan Assistant for Active Cooling](#)

[Fan Wiring Diagram](#)

[Active Cooling Programming Guide](#)

[Torque Specifications](#)

[trekMount Technical Drawing & Dimensions](#)

What's included

trekMount Solo

1. Modular mounting bracket
2. Mounting template
3. Screws for mounting
4. Cable protection for passthrough
5. Cable management anchors and zip-ties
6. Active cooling fans
7. Component mounting guidance

trekMount Ready

1. Everything included with trekMount Solo
2. Pre-mounted components (components purchased separately)
3. Pre-wired components (including wire, lugs, and heatshrink)
4. Pre-programmed components
5. Complete system design & wiring diagram

Installation

Using the Mounting Template

The provided mounting template includes;

1. Mounting holes for Inverter/Charger mounting plate placement
2. Mounting holes for the top two holes on either side of trekMount

The template ensures;

1. Inverter/charger is centered behind trekMount bracket
2. Inverter/charger status window lines up in the cutout on trekMount
3. Inverter/charger cable housing cover is centered and fully accessible behind trekMount

Installing Inverter/Charger

After all mounting holes from the template have been pre-drilled, install the Inverter/Charger mounting bracket, hang the inverter, and install any additional mounting screws to keep the inverter in place.

Note: Be sure to reference and follow all mounting instructions from the Inverter/Charger manufacturer.

Mounting trekMount

Once the Inverter/Charger is in position, install x2 screws into the holes that were pre-drilled for trekMount using the mounting template. The top two mounting holes on trekMount are key-holed so that it can be hung easily first, and then secured.

Component Wiring Connections

Connections made by Trek Systems

These are the components we'll mount, wire and program (cables, lugs, and heat shrink included for all circuits):

- x1 Victron MPPT (all models are compatible, excluding RS series)
- x1 PV Disconnect
- x1 Victron DC-DC charger (all models are compatible, excluding Orion XS 1400)
- x1 Lynx Distributor
- x1 Lynx Shunt
- x1 Lynx BMS or Clean Install Kit (w/ Disconnect Switch and SmartShunt)
- x1 Victron DC-DC step-down converter (for 24V or 48V systems)
- x1 Cerbo GX
- x1 GX Touch 50 with GX Touch 50 wall mount
- x1 BatteryProtect (all Victron models are compatible)
- x1 MultiPlus-II 3kVA (12V, 24V or 48V)
- x2 Fans for Active Cooling (these turn on/off with the built-in inverter fans)

[Complete wiring diagram](#) included

Note: At this time we are only able to mount components sourced from Trek Systems.

Optional add-ons:

- x1 DC Fuse Block and sealed busbar
- x1 AC Input Breaker
- x1 AC Output Breaker
- x1 AC Distribution Panel
- x1 Peplink BR1 Mini Mobile Router + SIM install and configuration
- x1 GX LTE 4G
- x1 Arco Zeus High Energy Alternator Regulator
- x1 GX I/O extender
- x1 SeeLevel Soul Tank Monitoring Unit
- Additional MPPTs
- Additional DC-DC Chargers or Converters

Component Wiring Connections (Continued)

Remaining Connections needed

These are the connections you will make on-site. Typically, these are connections that bridge the energy system and the platform it's powering.

Note: Consider leaving a bit of extra wire where applicable, in the event trekMount needs to be removed for inverter replacement.

Inverter/Charger DC connections

Once the Inverter/Charger is mounted, and trekMount is mounted ovetop, you may now terminate the Inverter/Charger DC cables. These are provided with trekMount Ready.

1. Remove the Inverter/Charger cable housing cover.
2. Remove the Lynx Distributor cover.
3. Use the diagram to identify which position to terminate Inverter/Charger DC cables on the Lynx Distributor
4. Route cables through the cable entry housing on Inverter/Charger
5. Connect Positive and Negative cables to DC terminals of Inverter/Charger

Inverter/Charger AC connections

Note: These connections only need to be made if AC Distribution is not included with your trekMount.

Refer to your wiring diagram for specific AC input & output connections.

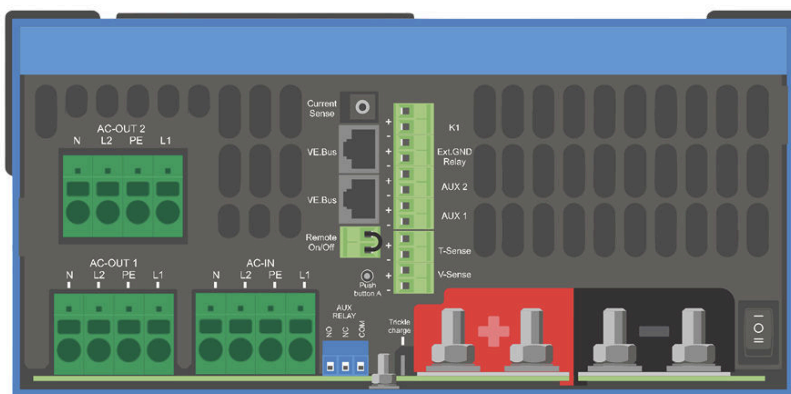

The inverter/charger(s) will be installed in-line between the shore power inlet and AC Distribution panel. If there's an onboard generator, then the inverter/charger will be wired between the automatic transfer switch output and AC distribution panel.

The AC terminals on the inverter/charger can be a bit difficult to work with when securing cables. To make installation easier, use a WAGO 210-719 tool to release the terminal clamps. This allows the wires to be inserted more easily. Once the wires are in place, remove the tool and perform a gentle tug test to ensure they are fully seated and secure.



Note: Do not invert neutral and phase when connecting the AC wiring.

For mobile applications it is important that fine & flexible stranded wire be used. Avoid connecting the inverter/charger to wires with rigid strands. Wires with rigid strands are not suitable for the inverter/charger AC connectors, leading to poor contact and the risk of disconnection.

Ferrule Pin and stripping length for the AC wiring is 0.7 inch (18 mm).

AC/DC Distribution Access Plate

When AC/DC distribution is requested, the left side of trekMount (when looking from the front) is removable with x4 screws located in each corner. This is the *AC/DC Distribution Access Plate*, and is designed so the installer may easily access the following:

- Main AC In/Out breaker wiring
- AC branch circuit wiring
- DC negative branch circuit connections

AC Distribution

When AC Distribution is requested, trekMount Ready is standardized with the following;

- x1 AC Input Breaker, one side pre-wired to the Inverter/Charger AC Input terminals
 - **Installer Note** - the other side to be wired to the shore power inlet
- x1 AC Output Breaker, one side pre-wired, ready to connect to the Inverter/Charger AC Output terminals. The other side pre-wired to the AC Distribution panel.
- x1 AC Distribution Panel
 - **Installer Note** - connect all 120V load, Hot connections to the individual branch circuit breakers.
 - Connect AC Neutral and Ground connections to the provided busbar (to be mounted on the wall next to the Inverter/Charger

Main DC Feeder

Note: These connections only need to be made if DC Distribution is not included with your trekMount.

If DC Distribution is not included with your trekMount, you will route the positive OUT connection from the Smart Battery Protect (or from the 24/12 or 48/12 converter) to your DC Distribution. The DC Distribution will require a negative connection originating at the negative bus Lynx Distributor.

DC Branch Circuits

Positive Connections

When DC distribution is requested, trekMount Ready is standardized with x2 [Egis 8+2 DC Fuse Blocks](#). This ensures that, in the event trekMount must be removed, DC loads can be disconnected easily.

Each fuse block utilizes x2 Molex MX-150 4 position connectors. Installers have the following options for connecting to the Egis Fuse Block;

1. Order x2 [MX-150 4 Position Harnesses](#) per fuse block. Harness wires will be spliced with all DC positive branch circuits.
2. Order x2 [Egis Conn Kit, MX-150 4 Position](#) per fuse block. All DC positive branch circuits will be terminated via molex connectors.

Negative Connections

When DC distribution is requested, trekMount Ready is standardized with x1 [Egis 12 Position Sealed Busbar](#), located on the backside of the AC/DC Distribution Access Plate.

Installers have the following options for connecting to the Egis 12 Position Busbar

1. Order x1 [Egis Conn Kit, MX-150 12 Position](#). If more than 12 positions are required, the remaining DC negative branch circuits may be terminated on the M8 stud.

Alternator Charging

Connect positive and negative cables from vehicle start battery to DC-DC charger input terminals.

Note: It's best practice to include a fuse or breaker near the starter battery. For this reason, trekMount Ready does not include circuit protection on the input side of the DC-DC charger.

Solar Panels

Connect cables from solar array (up to 10AWG) to included PV Disconnect Switch.

Battery Cables

Safety Note: Ensure Main Battery Disconnect switch is OFF prior to connecting battery cables.

Note: It's best practice to include a fuse or breaker near the battery bank. For this reason, trekMount Ready does not include circuit protection for the main battery cables. Be sure to add this prior to connecting trekMount to batteries.

When using the Lynx Clean Install Kit with a Disconnect Switch and SmartShunt, connect the positive cable to the disconnect switch, and the negative cable to the SmartShunt.

When using a Lynx BMS, take care to terminate the battery cables on the appropriate busbars of the Lynx BMS.

Double check all connections, torque, and confirm proper polarity prior to turning the Main Disconnect Switch on.

Self Installing components on trekMount Solo

trekMount Solo requires the user to install their own components. Refer to the 'Mockup Render' provided from Trek Systems for placement of components that have pre-determined, threaded M4 holes.

When mounting components that do not have pre-determined mounting holes, follow instructions below to mark and drill your own holes.

1. mark the position of the mounting holes
2. drill through with 11/64" bit
3. Mount with an M4 x 12mm screw and an M4 washer & nut on the backside.

If deciding to drill and tap M4 threads, use a fresh, 3.3mm drill bit and an M4 x 0.7mm thread tap. Be sure to keep the drill bit perpendicular to the trekMount so the hole is oriented correctly.

Startup Procedure

1. Ensure shore power is disconnected
2. Ensure the PV breaker is **OFF** (if system has solar)
3. Ensure the battery disconnect is **OFF**
4. Connect your battery bank to the positive & negative input connections - refer to your system diagram for specifics
5. Verify proper polarity and ensure battery connections are torqued
6. Verify battery bank voltage matches system voltage (ie. battery bank should be the same voltage as inverter/charger)

7. Turn the battery disconnect **ON**
8. Turn on the inverter/charger by flipping the rocker switch on the bottom to the "**I**" position
9. Turn the PV disconnect **ON** to enable solar charging

Victron Controls Orientation

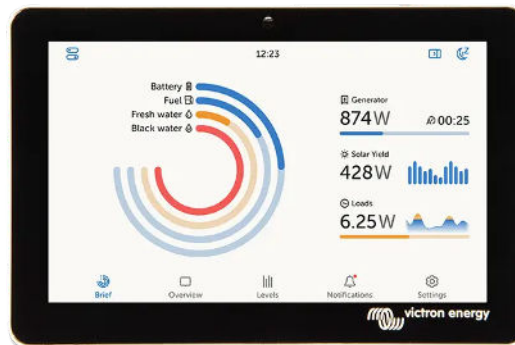

You can view your system overview by accessing the GX Touch Screen.

Inverter/Charger Controls Overview

The only setting you may need to regularly adjust is the **Input Current Limit**. This will limit the amount of power the Inverter/Charger will pass through from shore power so that you don't trip a breaker. It should be adjusted to match the type of service being connected to (50A, 30A, 15A).

You can access it by navigating to "Device List" and selecting the MultiPlus. In addition, within this menu you can turn the inverter On/Off.

Connecting to WiFi

Within the settings menu, you can also connect the Cerbo to WiFi, allowing remote access to your system from anywhere using VRM. Read about setting this up in the guide linked below:

<https://trek.systems/wp-content/uploads/2025/09/Preparing-for-Remote-Programming-Cerbo-GX-VRM.pdf>

This concludes the brief Victron Energy orientation. In most scenarios, the Victron system should operate without the need for much user input. In other words, the system is designed to be forgotten about (except for the few settings mentioned above).

Programming Victron Inverter/Charger Fan Assistant for Active Cooling

trekMount Solo comes mounted with x2 fans for active cooling. The voltage of these fans are matched to the voltage of the system. After the fans are wired according to the wiring diagram, you will need to program the Assistants in the MP-II. This will ensure that when the MP-II fan is ON, then the active cooling fans turn ON, when the MP-II fan is OFF, then the active cooling fans turn OFF.

If you have a trekMount Ready, you can disregard these steps as the system is already pre-wired and programmed for active cooling. Simply wire the labelled cables into the blue AUX relay of the MultiPlus.

If you are using the trekMount Solo, follow instructions below to set up active cooling.

Fan Wiring Diagram

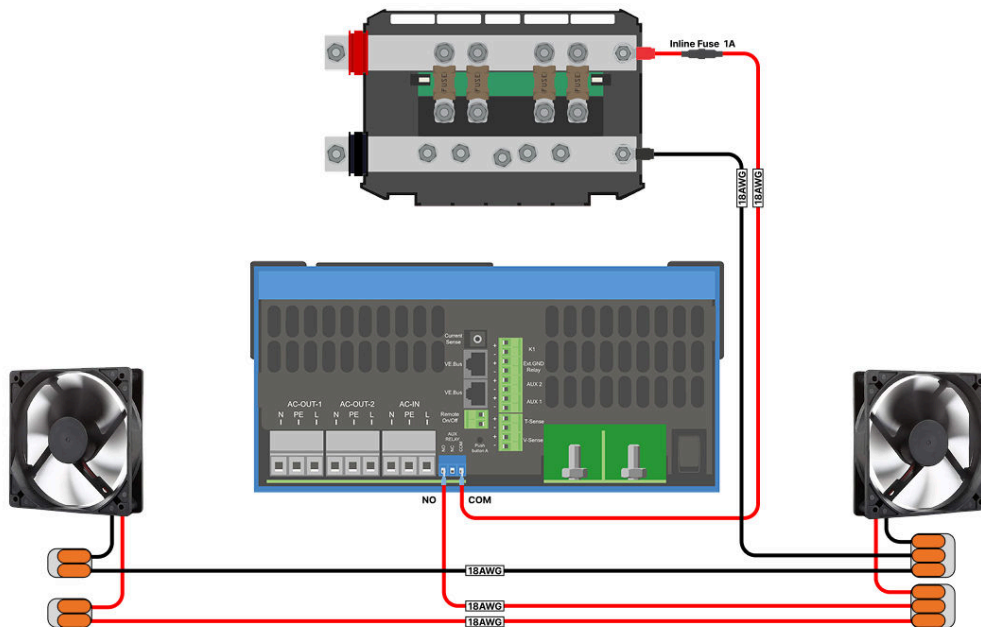

Note: MultiPlus Inverter/Charger AUX relays are rated for 4A up to 35VDC and 1A up to 60VDC.

Always use properly sized circuit protection and wire for the application.

Active Cooling Programming Guide

This guide is intended to give step-by-step instructions to implement active cooling with external fans that are triggered by a Victron Inverter/Charger's aux relay and an assistant that will enable the fans whenever the internal fan of the inverter/charger is activated.

This configuration can be done remotely through VRM or locally using an MK3-USB Adapter.

1. Open VE Configure 3 and connect your Inverter/Charger.
2. Disable Virtual Switch



3. Navigate to Assistants > Add Assistant > Relay > Programmable Relay

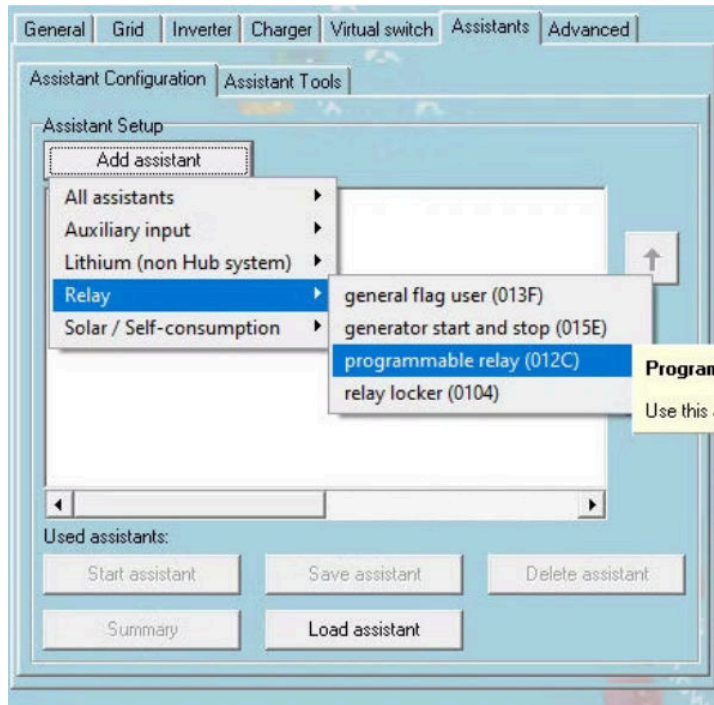

4. Click Start Assistant

5. Follow all prompts

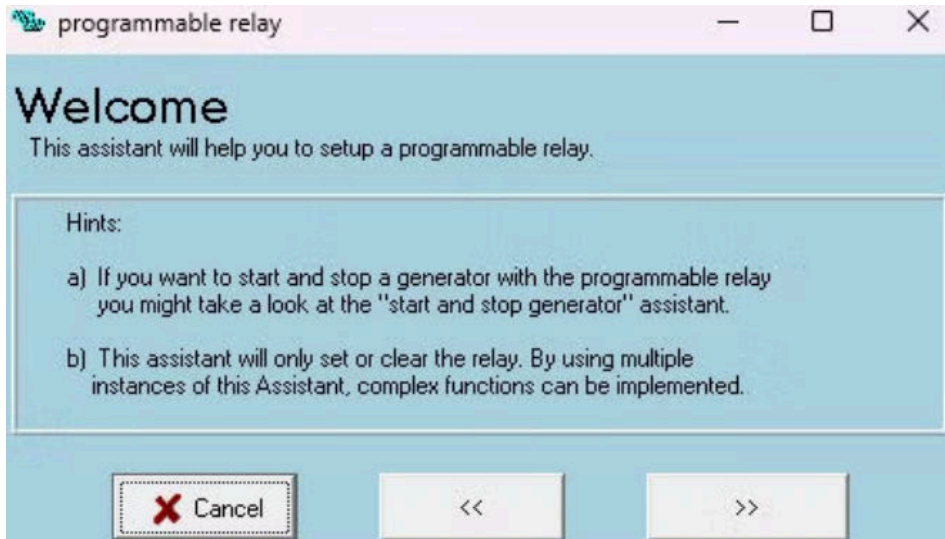

6. Select 'Use primary programmable relay'.

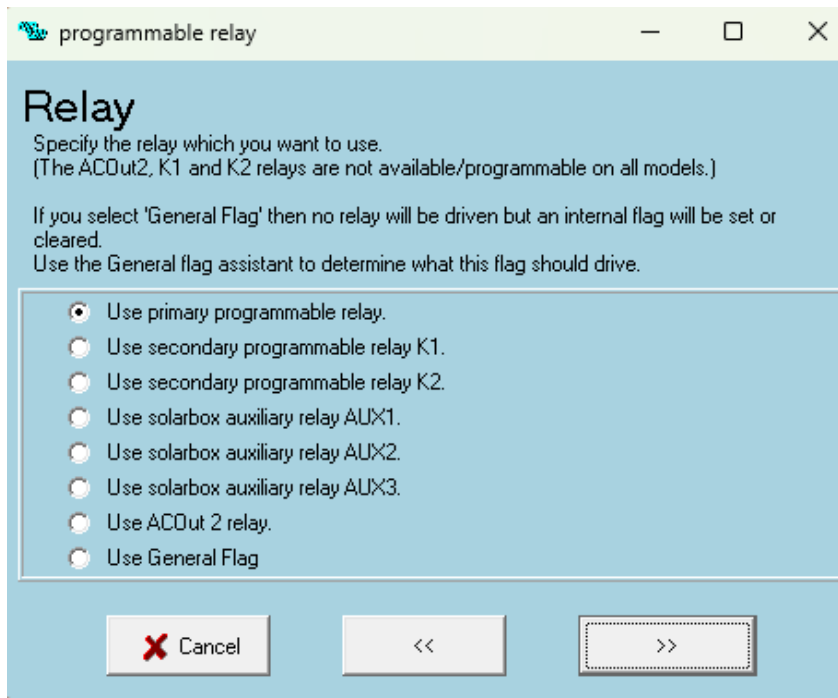

7. Select 'Set relay on'.

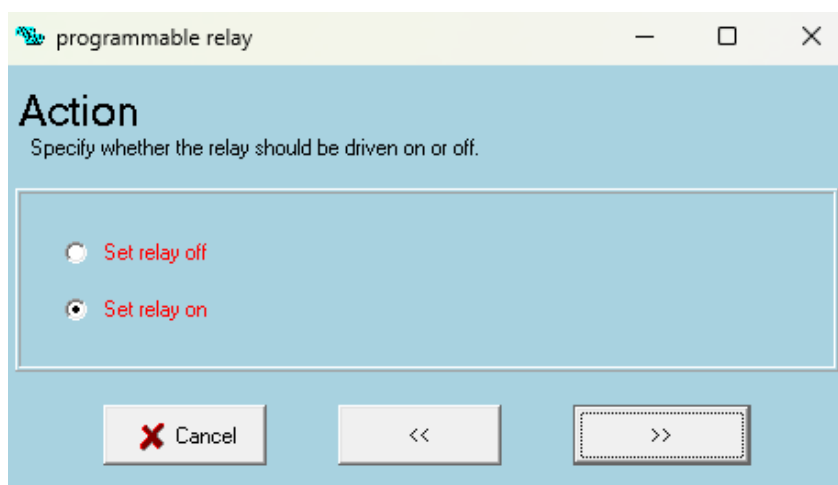

8. Select 'Fan' Switch Condition.

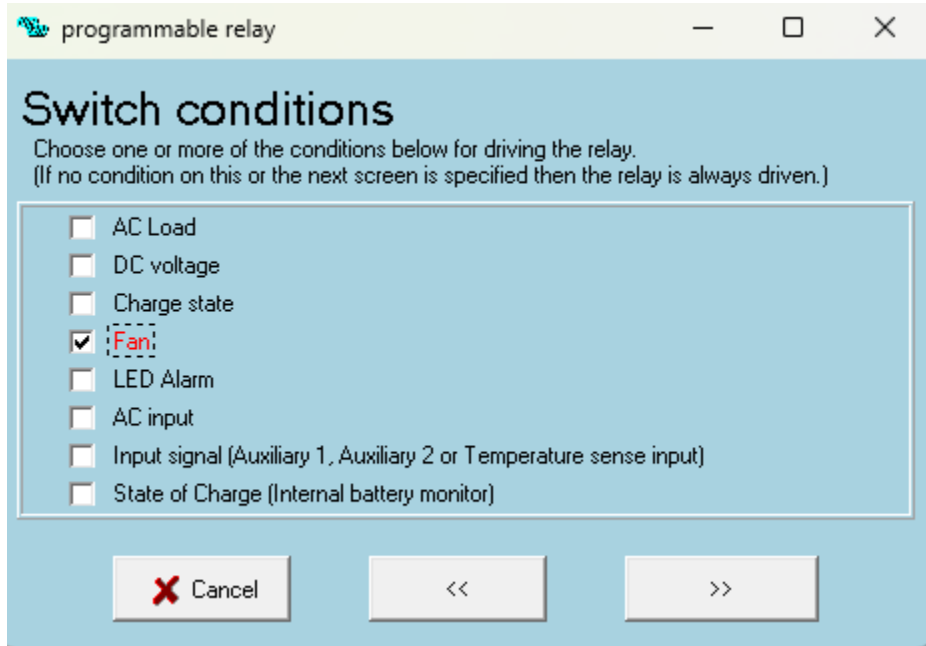

9. No selection is needed for extra drive options, you can skip this step.

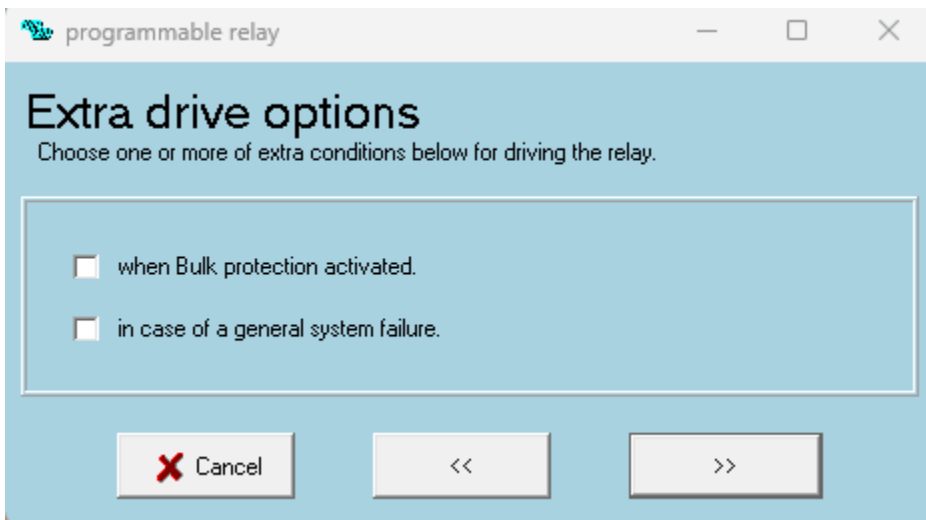

10. Set to: when fan is ON for 5 seconds.



11. Now we need to add a second assistant to turn the fan OFF. Navigate to Assistants > Add Assistant > Relay > Programmable Relay again.

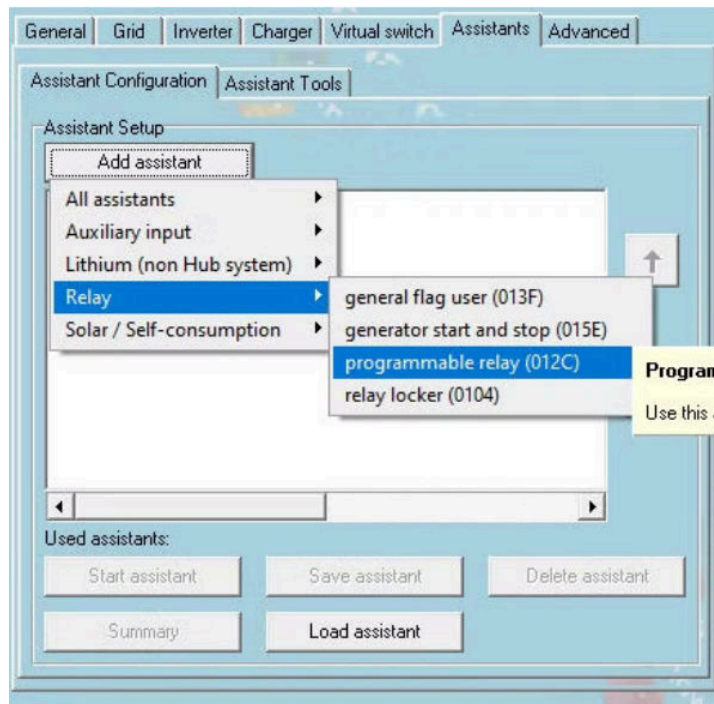

12. Click Start Assistant

13. Follow all prompts

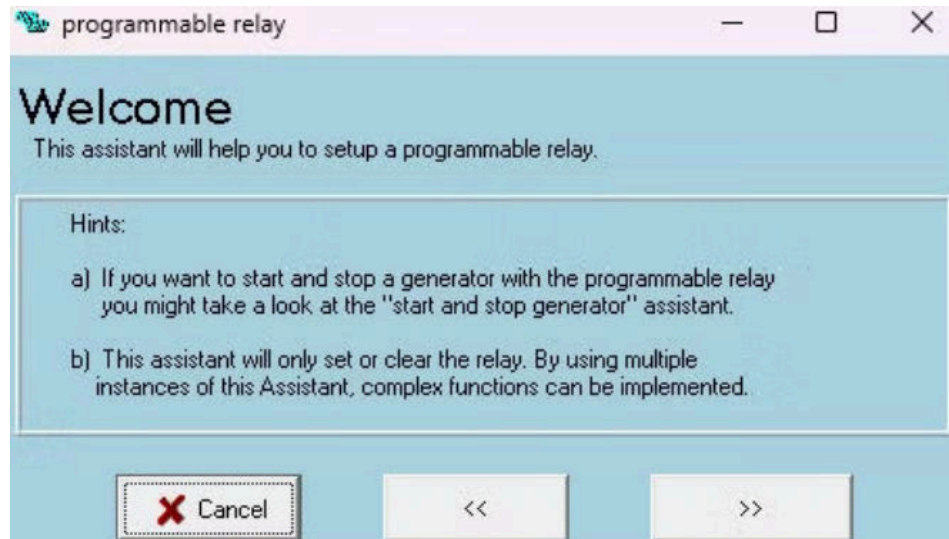

14. Select 'Use primary programmable relay'.

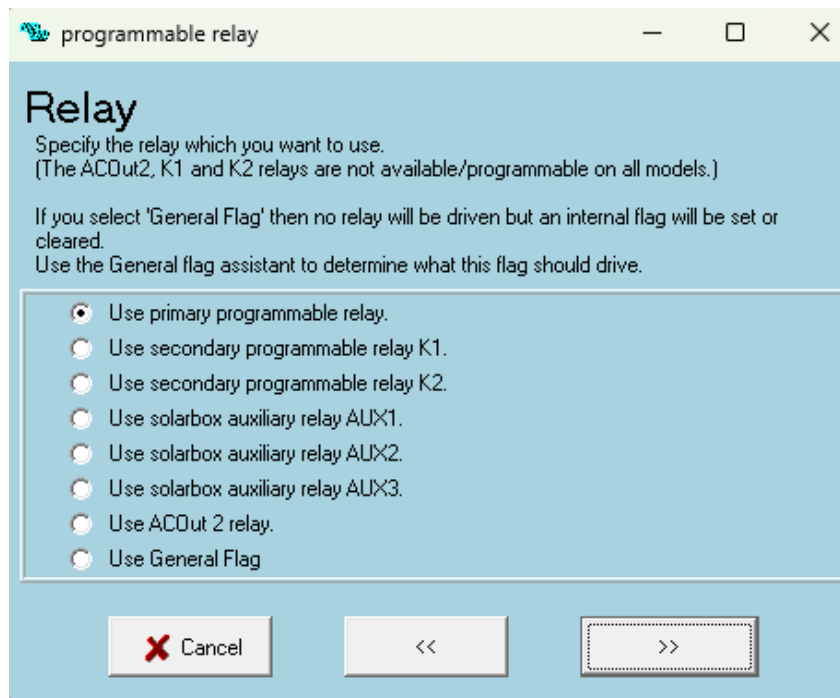

15. Select 'Set relay off'.

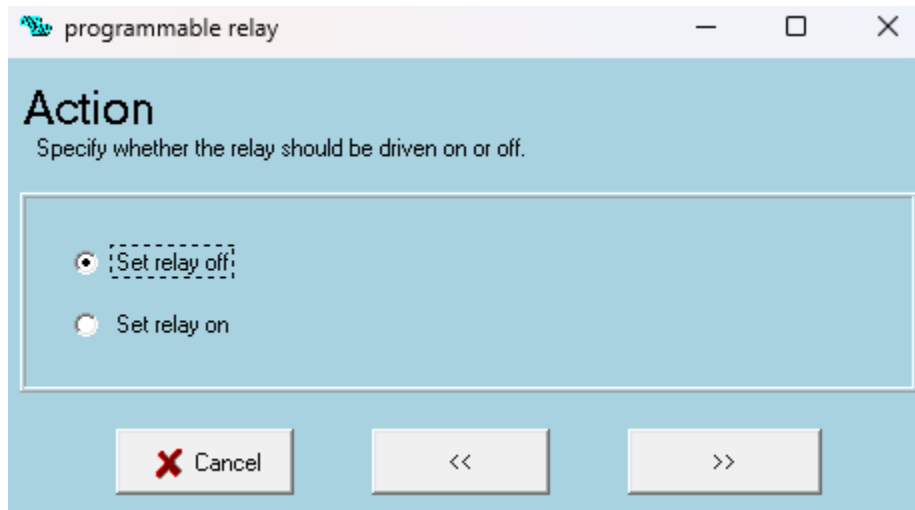

16. Select 'Fan' Switch Condition.

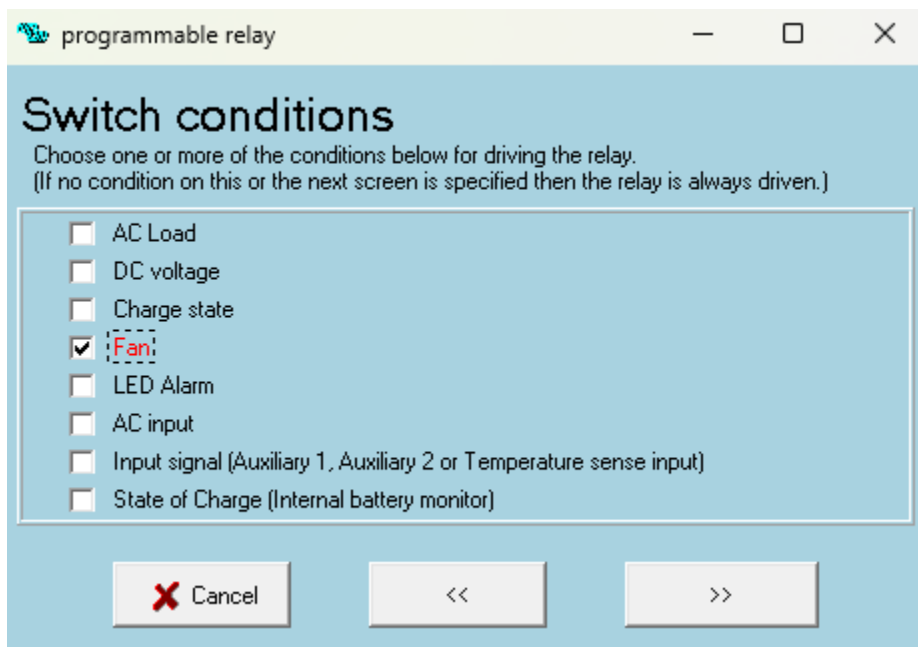

17. No selection is needed for extra drive options, you can skip this step.

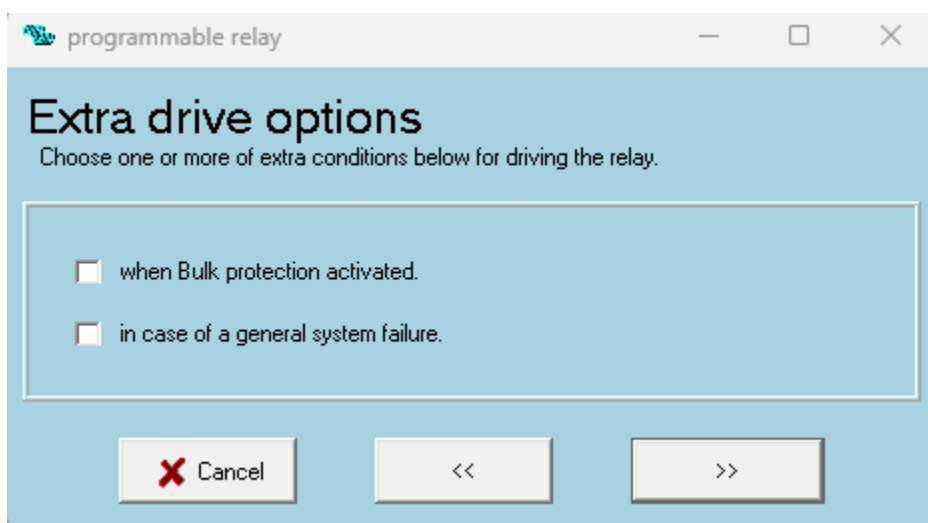

18. Set to: when fan is OFF for 5 seconds.

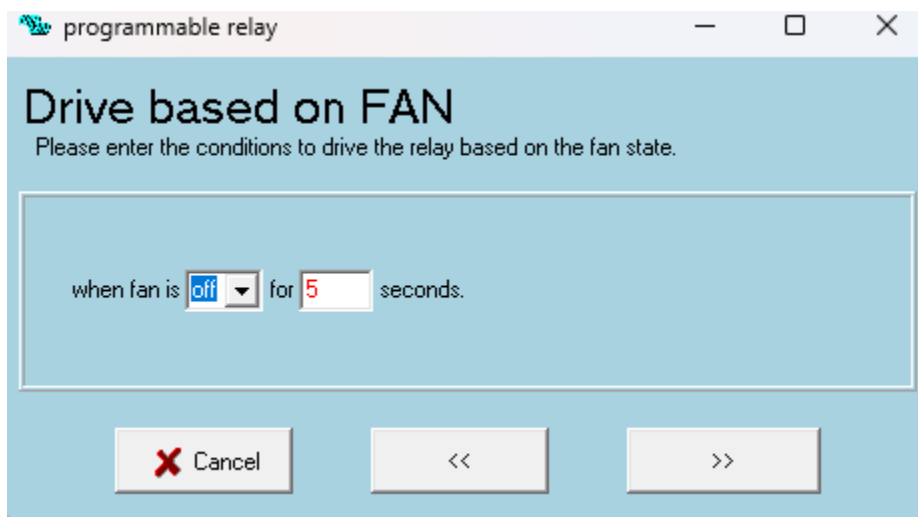

19. If connected with an MK3-USB press “Send Settings” to apply these changes.

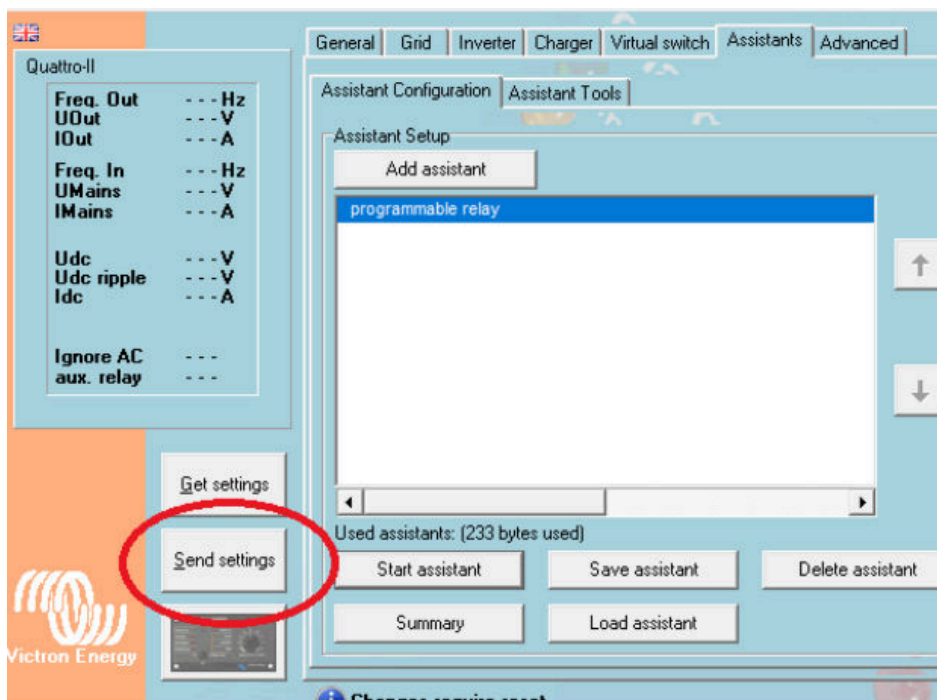

12. If you're using Remote VE Configure, close out of the program and re-upload the Configuration file through VRM.

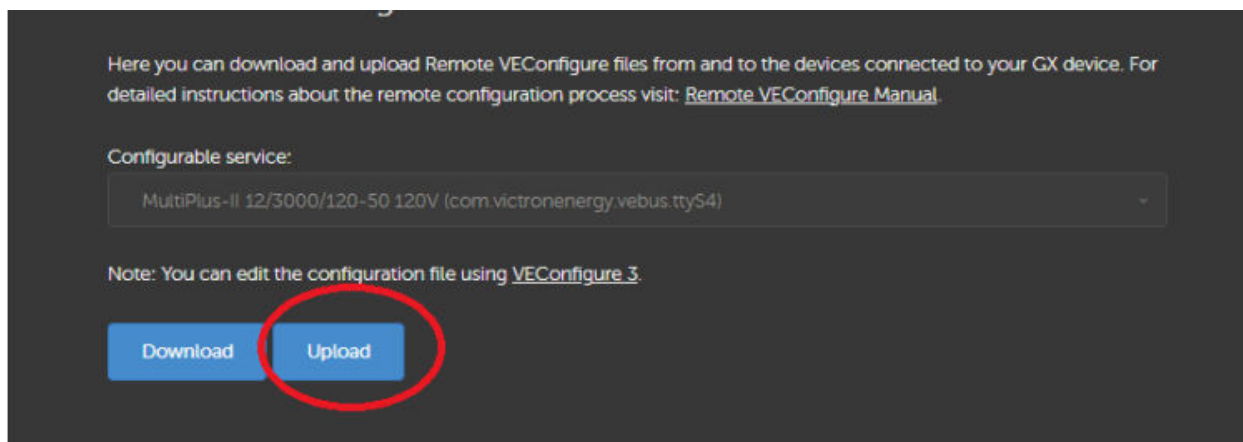

Congratulations! Your inverter/charger is now set up for active cooling and will drive the fans to engage when the internal fan of the inverter/charger is activated.

Torque Specifications

For more information, follow the links below to individual product pages. If an item is not found in the table below, please reach out to Trek Systems support for assistance.

Brand	Item	SKU	Image	Bolt Size	Torque
Victron	Lynx Smart BMS 500 NG	LYN034160310		M10	33Nm
Victron	Lynx Distributor	LYN060102010		M8	14Nm
Victron	Lynx Distributor	LYN060102010		M10	33Nm
Victron	MultiPlus-II	All SKUs		M8	12Nm
BEP	Battery Disconnect Switch	770-EZ		M10	13.5Nm
Victron	Smart Shunt 500A IP65	SHU065150050		M10	21Nm
Victron	Smart Battery Protect 65A	BPR065022000		M6	5Nm
Victron	Smart Battery Protect 100A	BPR110022000		M8	9Nm
Victron	Smart Battery Protect 220A	BPR122022000		M8	9Nm

Victron	Smart Battery Protect 48V 100A	BPR110048000		M8	9Nm
Victron	250A Busbar 4 position	VBB125040010		5/16"	13Nm

trekMount Technical Drawing & Dimensions

